



LED SPECIFICATION

Part No.: 05W580ERC



ATTENTION
OBSERVE PRECAUTIONS
FOR HANDLING
ELECTROSTATIC
DISCHARGE
SENSITIVE
DEVICES

Features:

- Single color
- High bright output
- Low power consumption
- High reliability and long life

Descriptions:

- Dice material: AlGaInP
- Emitting Color: Super Bright Red
- Device Outline: ϕ 5mm Round Type
- Lens Type: Water Clear

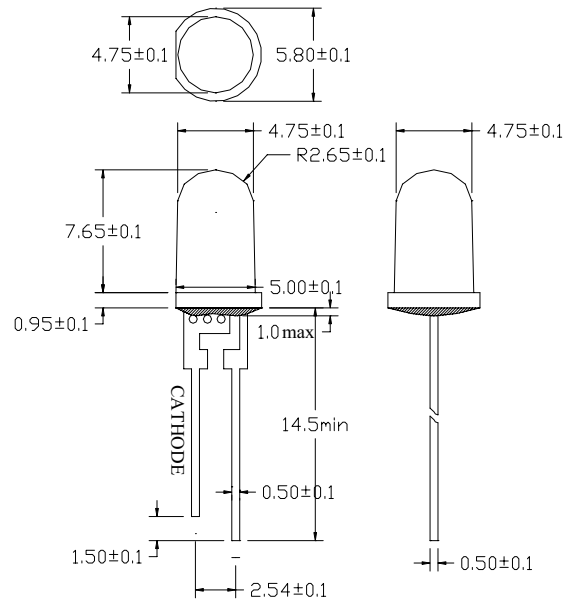

NOTE:

- All dimensions are millimetres.
- Tolerance is ± 0.25 mm unless otherwise noted

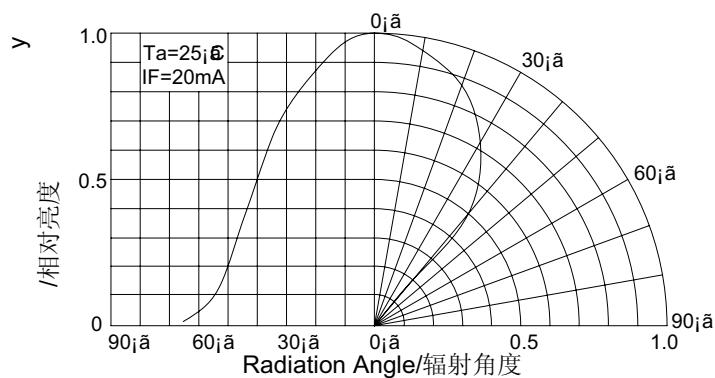



LED SPECIFICATION

Part No.: **05W580ERC**

Absolute maximum ratings (Ta = 25°C)

Parameter	Symbol	Test Condition	Value		Unit
			Min.	Max.	
Reverse Voltage	V _R	I _R = 30 μ A	5	--	V
Forward Current	I _F	----	----	100	mA
Power Dissipation	P _d	----	----	0.5	W
Pulse Current	I _{peak}	Duty=0.1mS, 1kHz	----	200	mA
Operating Temperature	T _{opr}	----	-20	+85	°C
Storage Temperature	T _{str}	----	-25	+100	°C

Electrical and optical characteristics (Ta = 25°C)

Parameter	Symbol	Test Condition	Value			Unit
			Min.	Typ.	Max.	
Forward Voltage	V _F	I _F = 100mA	----	2.1	2.5	V
Reverse Current	I _R	V _R = 5V	----	----	30	μ A
Wavelength	wd	I _F = 100mA	618	624	627	
Luminous Flux	Φ _v	I _F = 100mA	----	10	----	lm
Color Temperature	CCT	I _F = 100mA	----	----	----	K
Viewing Angle	2 θ 1/2	I _F = 100mA	----	85	----	Deg.

Luminous Flux Bins (Ta = 25°C)

Unit:lm

Bin	A	B	C			
Min	0	5	10			
Max	5	10	15			



LED SPECIFICATION

Part No.: 05W580ERC

Typical electrical/optical characteristic curves:

Fig1. 正向电流 Vs 正向电压

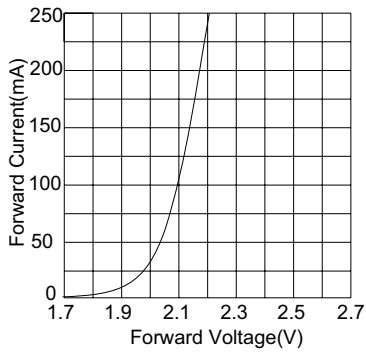

Fig2. 相对亮度 Vs 正向电流

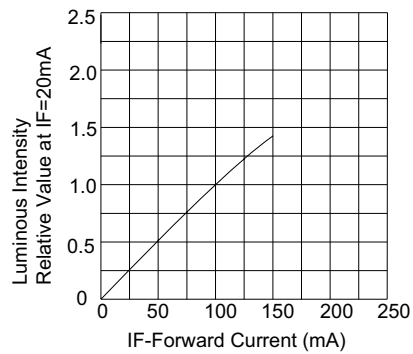

Fig3. 正向电流 Vs 环境温度

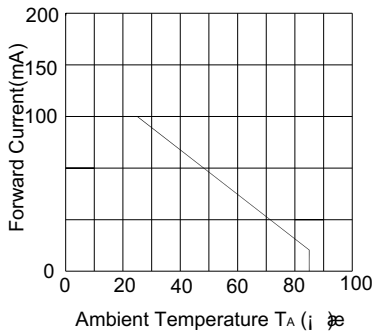

Fig4. 相对亮度 Vs 环境温度

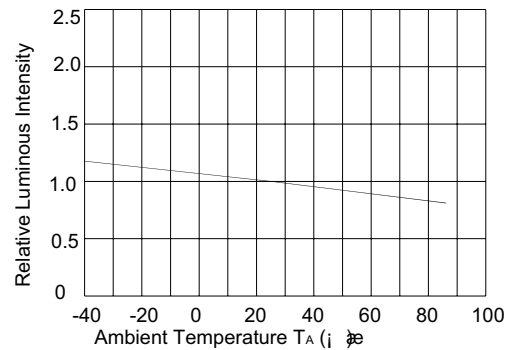

Fig.5 辐射强度 Vs. 波长

